

# CHFB 浙豪

**温州浙豪防爆电气有限公司**  
WENZHOU ZHEHAO EXPLOSION-PROOF ELECTRIC CO.,LTD

地址Add : 浙江省乐清市柳市镇东岸工业区  
Industrial Dongan Liushi Town Yueqing City Zhejiang China

电话TEL : 0086-577-61771116

传真FAX : 0086-577-61771119

网址Http : [www.cnzhehao.com](http://www.cnzhehao.com)

E-mail: [zh@cnzhehao.com](mailto:zh@cnzhehao.com)





Wenzhou Zhehao  
Explosion-proof Electric  
Co.,ltd

温州浙豪防爆电气有限公司

[www.cnzhehao.com](http://www.cnzhehao.com)



**CHFB** 浙豪防爆



## 公司简介

温州浙豪防爆电气有限公司位于国家享有美誉之称的中国电器之都乐清市，是一家专业生产厂用，煤矿，船舶，海洋等平台使用的防水防尘防爆电器：防爆信号灯，防爆按钮，防爆带灯按钮，防爆控制开关，防爆电位器等防爆控制元件。

浙豪防爆生产的防爆产品全部采用国际IEC60079、IEC61241标准及国家GB3836标准，公司质量保证体系完善，管理体制国际化。现拥有一支实力雄厚的技术队伍，不断开发国内外高端产品。

浙豪防爆产品被广泛用于石油，化工，航天，煤炭，电力，铁路，冶金，船舶，公安，消防，水利，市政，电信，潜水救援等行业。

浙豪防爆始终坚持“严格管理，质量优先，不断创新，与时俱进”的发展理念，竭诚欢迎中外客户，共创新辉煌！

## COMPANY PROFILE

Wenzhou ZheHao Explosion-proof Electric Co., Ltd., located in Yueqing city that enjoys the reputation of China electrical Capital, is a professional manufacturer for explosion-proof, water-proof and dust-proof electric products, such as explosion-proof signal lamp, explosion-proof pushbutton switches, explosion-proof pushbutton with lamps, explosion-proof control switches, explosion-proof potentiometers and explosion-proof control components, which are widely used for coal mine, ships and marine platforms.

With perfect quality control and international management systems, ZheHao's products are manufactured strictly according to international standard of IEC60079 and IEC61241, and national standard of GB3836, besides, Zhehao also have a strong R & D technical team to continue developing high-end products.

ZheHao Explosion-proof products are widely used in petroleum, chemical, aerospace, coal, electric power, railway, metallurgy, shipbuilding, public security, fire fighting, water, municipal works, telecommunications, and diving rescue industry, etc.

ZheHao Ex always adhere to "strict management, quality first, continuous innovation and keeping pace with the times"! ZheHao Ex welcome domestic and foreign customers! Let's create brilliancy together!

### ● 危险场所划分 Classification of hazardous places

- 根据爆炸环境出现的频率和持续的时间把危险场所划分为不同的区域。  
气体场所划分为三个区域：0区、1区和2区。
- Hazardous places are classified different zone depending on the frequency and duration of the explosive atmosphere.  
Gas area is classified into three zones: Zone 0, Zone 1 and Zone 2

#### 0 区 Zone 0

爆炸性环境中的爆炸混合物以气体、蒸汽或薄雾形式连续出现或长时间存在的场所。

A place in which an explosive atmosphere consisting of a mixture with air of flammable substances in the form of gas, vapour or mist is present continuously or for long periods.

#### 1 区 Zone 1

在正常运行时，爆炸性环境中可能出现气体、蒸汽或薄雾形式的爆炸性混合物场所。

1区是防爆电气设备的典型应用场所

A place in which an explosive atmosphere consisting of a mixture with air of flammable substances in the form of gas, vapour or mist is likely to occur in normal operation occasionally.

#### 2 区 Zone 2

在正常运行时，爆炸性环境中不太可能出现气体、蒸汽或薄雾形式的爆炸性混合物，如果现也只是偶尔发生并且短时间存在的场所。通常情况下，“短时间”是指持续时间不多于2个小时。

A place in which an explosive atmosphere consisting of a mixture with air of flammable substances in the form of gas, vapour or mist is likely to occur in normal operation but, if it does occur, will persist for a short period only. As a rule, "for short period only" means no more than 2 hours.

- 粉尘场所分为三个区域：20区、21区、22区。
- The dust area is classified as three zones: zone20、zone21、zone22

#### 20 区 Zone 0

在正常运行过程中，可燃性粉尘连续出现或经常出现，其数量足以形成可燃性粉尘与空气混合物和/或可能形成无法控制和极厚的粉尘层的场所及容器内部。

Area in which combustible dust, as a cloud, is present continuously or frequently, during normal operation, in sufficient quantity to be capable of producing an explosive concentration of combustible dust in mixture with air and/or where layers of dust of uncontrollable and excessive thickness can be formed.

#### 21 区 Zone 21

在正常运行过程中，可能出现粉尘数量足以形成可燃性粉尘与空气混合物但未划入20区的场所。该区域包括，与充入或排放粉尘直接相邻的场所、出现粉尘层和正常操作情况下可能产生可燃浓度的可燃性粉尘与空气混合物的场所。

Area not classified as zone20 in which combustible dust, as a cloud, is likely to occur during normal operation, in sufficient quantities to be capable of producing an explosive concentration of combustible dust in mixture with air. This zone can include, among others, areas in the immediate vicinity of powder filling or emptying points and areas where dust layers occur and are likely in normal operation to give rise to an explosive concentration of combustible dust in mixture with air.

#### 22 区 Zone 22

在异常条件下，可燃性粉尘云偶尔出现并且只是短时间存在、或可燃性粉尘偶尔出现堆积或可能存在粉尘层并且产生可燃性粉尘空气混合物但未划入21区的场所，如果不能保证排除可燃性粉尘堆积或粉尘层时，则应划分为22区。

Area not classified as zone 21 in which combustible dust clouds may occur infrequently and persist for only a short period, or in which accumulations or layers of combustible dust may be present under abnormal conditions and give rise to combustible mixtures of dust in air. Where, following an abnormal condition, the removal of dust accumulations or layers cannot be assured, then the area is to be classified zone 22.

## ● 温度组别 Temperature class

- 爆炸性气体引燃温度及设备允许最高表面温度分组：
- Ignition temperature of explosive atmosphere and classification of maximum surface temperature permitted by apparatus.

气体引燃温度 Ignition temperature(°C)	设备允许最高表面温度Maximum surface temperatures that apparatus peritted(°C)					
	T6(85°C)	T5(100°C)	T4(135°C)	T3(200°C)	T2(300°C)	T1(450°C)
85<T≤100						
100<T≤135						
135<T≤200						
200<T≤300						
300<T≤450						
450<T						

引燃温度 Ignition temperature  
 设备允许最高表面温度(°C) Maximum surface temperatures that apparatus peritted(°C)







- 爆炸性气体、蒸气的分级/允许使用设备级别
- Classification of gas and vapor / permitted apparatus classification

爆炸性气体、蒸气的分级 Classification of gas and vapor		允许使用设备级别 Permitted apparatus classification
A级 Class A	例如：丙烷、戊烷、苯、汽油、乙醇、乙醚、丙酮、甲胺等 Example: propane,hexane,benzene,gasoline,ethanol,acetaldehyde,acetone,methylamine	II A、II B或 II C II A、II B or II C
B级 Class B	例如：乙烯、二甲醚、焦炉煤气等 Example: ethylene,climethyl ether,coke over gas	II B、II C
C级 Class C	例如：氢气、乙炔和二硫化碳 Example: hydrogen,acetylene,carbon disulphide	II C

- 防腐电工产品标志
- Mark of anti-corrosive electrical products

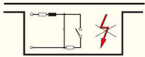

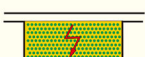

环境条件 Environment conditions	适用环境类别和标志 Applicable environment group and mark		
	0类 (轻度腐蚀环境) Group0(light corrosive environment)	1类 (中等腐蚀环境) Group1(middle corrosive environment)	2类 (强腐蚀环境) Group2(strong corrosive environment)
户内 Indoor	—	F1	F2
户外 Outdoor	W	WF1	WF2





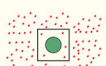
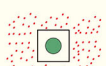

### ● 防爆原理 Explosion-proof Principle

防爆标准 Explosion-proof standard	防爆原理 Explosion-proof Principle	图解 Illustration
隔爆型 "d" Flame-proof "d" GB3836.2 IEC60079-1 EN60079-1	将设备在正常运行时,能产生电火花电弧的部件置于隔爆外壳内,隔爆外壳能承受内部的爆炸压力而不致损失,并能防止传播到外壳外。 A type of protection in which the parts which could ignite an explosive atmosphere are located inside an enclosure which can withstand the pressure of an explosion of the explosive mixture inside, and prevents the transmission of the explosion to the explosive atmosphere surrounding the enclosure.	
增安型 "e" Increased safety "e" GB3836.3 IEC60079-7 EN60079-7	在正常运行时不会产生电弧、火花和危险高温,在结构上再进一步采取保护措施,提高设备的安全性。 Additional measures provide a higher level of protection. This ensures reliable prevention of unacceptably high temperatures and sparks or electrical arcs, both on the internal and on the external parts of electrical equipment whose normal operation does not involve unacceptably high temperature sparks or arcing enclosure.	
本质安全型 "i" Intrinsically safe "i" GB 3836.4 IEC60079-11 EN60079-11	设备内部的电路在规定的试验条件下,正常工作或规定的故障状态下产生的电火花和热效应均不能点燃爆炸性混合物。 Intrinsically safe circuits are circuits in which no spark or thermal effect occurring under the test conditions laid down in the standard can ignite the explosive atmosphere of subgroups IIA, IIB and IIC or of an air/dust mixture. The test conditions cover normal operation and certain fault conditions stipulated in the standard.	
正压型 "p" Pressurized "p" GB 3836.5 IEC60079-2 EN60079-2	保持内部保护气体的压力高于周围,以免爆炸性混合物进入外壳,或使足量的保护气体通过外壳,使内部的爆炸性混合物的浓度降至爆炸下限以下。 Use of a protective gas preventing ignition inside an enclosure to prevent the formation of an explosive atmosphere inside the enclosure by maintaining a pressure greater than the that in the surrounding atmosphere.	
油浸型 "O" Oil immersion "o" GB 3836.6 IEC60079-6 EN60079-6	将电气设备的部件整个浸在保护液中,使设备不能够点燃液面上或外壳外面的爆炸性气体。 Parts which might ignite an explosive atmosphere are immersed in oil or other non-flammable, insulating liquid so that gases and vapours above the oil level and outside the enclosure cannot be ignited by electric arcs or sparks generated below the oil level.	
充砂型 "q" Powder filling "q" GB 3836.7 IEC60079-5 EN60079-5	电气设备的一种防爆型式,将能点燃爆炸性气体的被固定导电部件完全填入填充材料中,以防止点燃外部爆炸性气体环境。 By filling the enclosure with a finely grained powder, an arc within the enclosure is unable, with correct use, to ignite the explosive atmosphere outside.	
浇封型 "m" Moulding "m" GB 3836.9 IEC60079-18 EN60079-18	将可能产生点燃爆炸性混合物的部分浇封在复合物中,使它不能点燃周围的爆炸性气体。 The equipment are fully enclosed similar to the encapsulation type of protection e. g. in a casting compound, so that ingress of the outer atmosphere is prevented.	
n型 n Type GB 3836.8 IEC60079-15 EN60079-15	电器设备不能点燃周围的爆炸性气体(在正常的工作条件下和在确定的非正常工作条件下)。 The systems, equipment and components are constructed in a way which ensures that they cannot turn into an ignition source under normal operation or in cases of faults.	2区 Zone 2 n型的几种保护方法: Several protection methods of type n.

● 国际防护等级标准 International protection code

IP

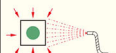
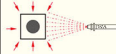
防外物进入外壳等级 Prevent solid object		
	试验Test	防护Protection
0	不做试验 Exempt from testing	本身固有的保护 Inherent protection
1		能防止直径大于50mm的固体类物进入体内 (如: 手的意外接触) Ingress of solid object dia. 50mm is protected (eg:accidental contact with the hand)
2		能防止直径大于12.5mm的固体类物进入体内 (如: 手指) Ingress of solid object dia. 12.5mm is protected (eg:finger)
3		能防止直径大于2.5mm的固体类物进入体内 (如: 工具, 导线) Ingress of solid object dia. 2.5mm is protected (eg:tools,wires)
4		能防止直径大于1.0mm的固体类物进入体内 (如: 小工具, 导线) Ingress of solid object dia. 1.0mm is protected (eg:small tools,wires)
5		防尘, 尘埃的进入量不能达到防护设备正常运转的程度 Can not completely protected against dust , but dust entried will not effect the normal running of electrical equipment
6		无尘埃进入 Completely protected against dust

防水进入外壳等级 Water-proof class		
	试验Test	防护Protection
0	不做试验 Exempt from testing	本身固有的保护 Inherent protection
1		滴水(垂直滴水)无有害影响。 Protected against vertically-falling drops of water (condensation)
2		当外壳从正常位置倾斜在15°以内时,垂直滴水无有害影响 Protected against drops of water falling in angle of 15° from the vertical
3		垂直成60° 范围以内的淋水无有害影响。 Protected against spraying water in angle of 60° from the vertical
4		任何方向溅水无有害影响 Protected against splashing water from all directions
5		任何方向喷水无有害影响 Protected against jets of water from all directions
6		猛烈海浪或强烈喷水时, 无有害影响 Completely protected against strong jets of water or heavy waves
7		防浸水影响 Protected against water dip
8		防潜水影响 Protected against water sink

## ● 设备保护级别 (EPL) 与使用区域对应关系

Corresponding relationship between distinction of equipment protection level (EPL) and zone

设备保护级别 Equipment protection levels	使用区域 Zone
Ga	0区 Zone 0
Gb	1区 Zone 1
Gc	2区 Zone 2
Da	20区 Zone 20
Db	21区 Zone 21
Dc	22区 Zone 22

## ● 防爆标志Ex-mark

- 爆炸性气体环境使用电气设备防爆标志:
- Ex-mark of electrical apparatus for explosive gas atmospheres

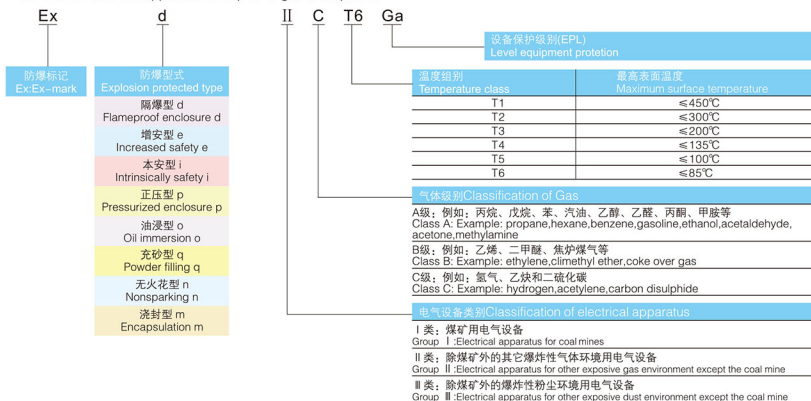

- 可燃性粉尘用电气设备防爆标志:
- Ex-mark of Electrical apparatus for ignitable dust  
中国GB标准 Chinese GB standard

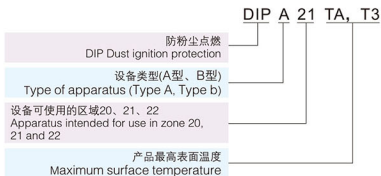

## 国际IEC标准 International IEC standard

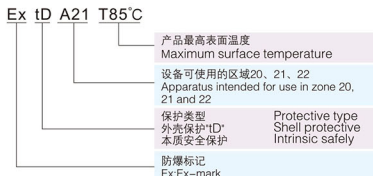

# Contents 目录

---

ZH-B款板后单元型防爆按钮、开关 ZH-B type explosion-proof pushbutton, switch of board back unit type	01
ZH-B款板后单元型防爆平钮 ZH-B type explosion-proof flat button of board back unit type	02
ZH-B款板后单元型防爆急停按钮 ZH-B type explosion-proof emergency stop button of board back unit type	03
ZH-B款板后单元型防爆二极开关 ZH-B type two position explosion-proof pushbutton switch of board back unit type	04
ZH-B款板后单元型防爆信号灯 ZH-B type explosion-proof signal lamp of board back unit type	05
ZH-B款板后单元型防爆信号灯带按钮 ZH-B type explosion-proof signal lamp with button of board back unit type	07
ZH-B款板后单元型防爆电位器 ZH-B type explosion-proof potentiometer of board back unit type	08
ZH-A款板前、C款板后防爆元件 ZH-A type board front, C type board back, explosion-proof component	09
ZH-A款板前、C款板后防爆平钮 ZH-A type board front, C type board back explosion-proof flat button	10
ZH-A款板前、C款板后防爆急停按钮 ZH-A type board front, C type board back Explosion-proof emergency stop button	12
ZH-A款板前、C款板后型防爆蘑菇按钮 ZH-A type board front, C type board back type explosion-proof mushroom button	14
ZH-A款板前、C款板后防爆二极开关元件 ZH-A type board front, C type board back 2-pole explosion-proof switch component	16
ZH-A款板前、C款板后防爆信号灯元件 ZH-A type board front, C type board back explosion-proof signal lamp component	18
ZH-A款板前、C款板后防爆信号灯带按钮元件 ZH-A type board front, C type board back explosion-proof signal lamp with button component	20
ZH-A款板前、C款板后防爆电位器元件 ZH-A type board front, C type board back explosion-proof potentiometer component	22
ZH-D款板后型防爆信号灯 ZH-D type board back type explosion-proof signal lamp	24
ZH-D款板后型防爆按钮 ZH-D type board back type explosion-proof push button	25
ZH-E款板后型防爆按钮(隔爆型) ZH-E type board back type explosion-proof push button(flameproof)	26
ZH-E款板后型防爆信号灯(隔爆型) ZH-E type board back type explosion-proof signal lamp(flameproof)	28
ZH-F款板后防爆信号灯元件 ZH-F type board back explosion-proof signal lamp component	29
ZH-F款板后型防爆按钮 ZH-F type board back type explosion-proof push button	31
ZH-BXK-L/G/S防爆防腐防尘控制箱(操作柱) ZH-BXK-L/G/S Explosion proof, corrosion proof and dust proof control box (Operating column)	33

# ZH-B款板后单元型防爆按钮、开关

ZH-B type explosion-proof pushbutton, switch of board back unit type

CHFB 浙豪

## 描述 Descriptions

板后单元型防爆元件的前端操作头标准直径为 $\Phi 30\text{mm}$ ，安装在1-6mm厚的面板上，可独立使用，广泛应用于琴台式控制设备和监控设备。根据用户要求可配柔性电缆。

板后单元型防爆按钮、开关可选用多种不同功能的按钮操作头、开关操作头。

板后单元型防爆信号灯元件采用LED光源，内设温度开关、有五种颜色可以选择。

- 按钮的标识牌符号经烧结后可永久保留。
- 板后单元型防爆开关的额定电流可达16A，机械寿命可达200万次。
- 板后单元型防爆信号灯具有高亮度、长寿命等特点，电气寿命可达30万小时以上。

The standard diameter of front neck for explosion-proof board back module is 30mm. Thickness of installing panel should be 1-6mm. Widely used in control device and monitoring equipment, and it can also be used separately. The flexible cable can be equipped according to the user's request.

A large number of versions of actuating elements are available for the button and indicator units

LED light source is used in explosion-proof signal lamp of board back module type, and thermal switch is also build-in. There are five color available.

- The laser mark of button are never fade.
- Rated current of board back module type explosion-proof switch is 16A, and its mechanical life is 2,000,000 times.
- The features of board back module type explosion-proof signal lamp are high brightness, long life, and its electric life is more than 300,000 hours.

## 型号及其含义 Model and meaning



## 主要数据 Main technical data:

防爆标志: Exde II C T6 DIP A21 TA,T6

适用范围: 用于1区和2区

使用环境温度:  $-60^{\circ}\text{C} \leq \text{Ta} \leq 55^{\circ}\text{C}$

防护等级: IP67 [配合操作头]

额定电压: 250V | 250V | 110V | 24V

使用类别: AC12 | AC15 | DC13 | DC13

额定电流: 16A | 10A | 0.5A | 1A

机械寿命: 200万次

电缆引入外径:  $\Phi 5.5-13\text{mm}$

符合标准: IEC60079 IEC61241  
EN60079 EN61241

Ex mark: Ex de II C T6 DIP A21 TA,T6

Application: zone 1 and zone 2

Ambient temperature:  $-60^{\circ}\text{C} \leq \text{Ta} \leq 55^{\circ}\text{C}$

Degree of protection: IP67(Match operation head)

Rated voltage: 250V | 250V | 110V | 24V

Category: AC12 | AC15 | DC13 | DC13

Rated current: 16A | 10A | 0.5A | 1A

Mechanical life: 2,000,000 times

Cable diameter:  $\Phi 5.5-13\text{mm}$

Standard: IEC60079 IEC61241

EN60079 EN61241

1区和2区 Zone 1 and zone 2

21区和22区 Zone 21 and zone 22

# ZH-B款板后单元型防爆平钮

ZH-B type explosion-proof flat button of board back unit type

## 订购规格 Order specifications

图样 Illustration	名称 Name	型号 Model	按钮触点 Button contact
	防爆平钮 Explosion-proof flat button	ZH-B11P	$\begin{matrix} 11 & 23 \\   &   \\ 12 & 24 \end{matrix}$ 1NO/1NC
		ZH-B02P	$\begin{matrix} 11 & 21 \\   &   \\ 12 & 22 \end{matrix}$ 2NC
		ZH-B20P	$\begin{matrix} 13 & 23 \\   &   \\ 14 & 24 \end{matrix}$ 2NO
	防爆双按钮 Explosion-proof double button	ZH-B11P2	$\begin{matrix} 11 & 23 \\   &   \\ 12 & 24 \end{matrix}$ 1NO/1NC
		ZH-B02P2	$\begin{matrix} 11 & 21 \\   &   \\ 12 & 22 \end{matrix}$ 2NC
		ZH-B20P2	$\begin{matrix} 13 & 23 \\   &   \\ 14 & 24 \end{matrix}$ 2NO

注：如无特殊要求，平钮、蘑菇钮、双按钮、二位置选择按钮、急停按钮均为常开一常闭，三位选择按钮为两常开，带灯钮：绿色、黄色、白色、蓝色均为常开，红色为常闭。

Note: if no special requirements, flat button, mushroom button, double button, two position selection button, emergency stop button are 1NO+1NC, three position selector button for two normally open, button with light: green, yellow, white and blue are one normally open, red color is one normally closed.

## 外型尺寸 Outline dimensions

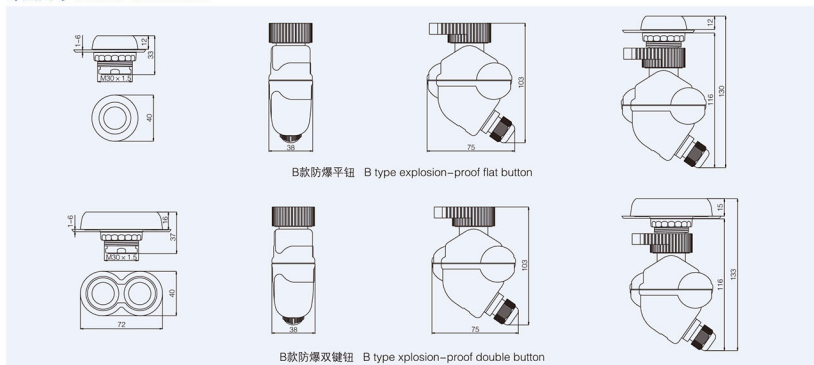

## 安装间距 Mounting distance

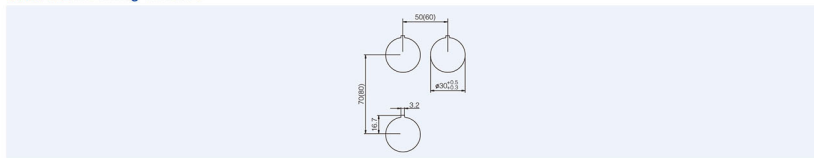

## ZH-B款板后单元型防爆急停按钮

ZH-B type explosion-proof emergency stop button  
of board back unit type

### 订购规格 Order specifications

图样 Illustration	名称 Name	型号 Model	按钮触点 Button contact
	旋式急停按钮 Rotary type emergency stop button	ZH-B11ZX	 1NO/1NC
		ZH-B02ZX	 2NC
		ZH-B20ZX	 2NO
	直拔式急停按钮 Pull type emergency stop button	ZH-B11ZB	 1NO/1NC
		ZH-B02ZB	 2NC
		ZH-B20ZB	 2NO
	蘑菇型按钮 Mushroom button	ZH-B11M	 1NO/1NC
		ZH-B02M	 2NC
		ZH-B20M	 2NO

### 外型尺寸 Outline dimensions





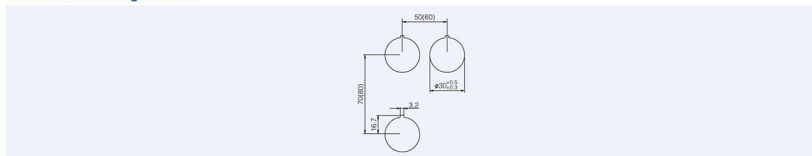





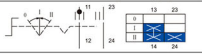

### 安装间距 Mounting distance



# ZH-B款板后单元型防爆二极开关

ZH-B type two position explosion-proof pushbutton switch of board back unit type

## 订购规格 Order specifications

图样 Illustration	型号 Model	标识牌 Label	操作位置接触图 Contact schematic for operating position
	ZH-B11X3F2	0 I II	
	ZH-B20X3F1	I 0 II	
	ZH-B20X3F2	I 0 II	
	ZH-B20X3	I 0 II	
	ZH-B11X3	0 I II	
	ZH-B20X2	0 I	
	ZH-B20X2F	0 I	
	ZH-B11X2	I II	
	ZH-B11X2F	I II	
	ZH-B11X3F1	0 · I	

## 外型尺寸 Outline dimensions

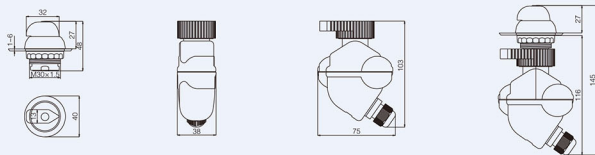

## 安装间距 Mounting distance

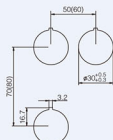

# ZH-B款板后单元型防爆信号灯

ZH-B type explosion-proof signal lamp of board back unit type

## 型号及其含义 Model and meaning

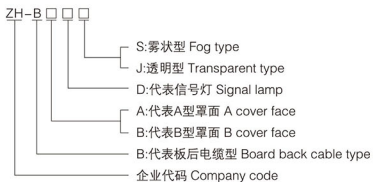

## 主要数据

防爆标志: Ex de II C T6 DIP A21 TA,T6

适用范围: 用于1区和2区

使用环境温度:  $-60^{\circ}\text{C} \leq \text{Ta} \leq 55^{\circ}\text{C}$

防护等级: IP67 (配合操作头)

额定电压: AC,DC6.3V~220V AC110V~380V

功耗:  $P_{\text{max}} \leq 1\text{W}$

光源: LED

电气寿命: 30万小时

电缆引入外径:  $\Phi 5.5\text{--}13\text{mm}$

符合标准: IEC60079 IEC61241 EN60079 EN61241

## Main technical data:

Ex mark: Ex de II C T6 DIP A21 TA,T6

Application: zone 1 and zone 2

Ambient temperature:  $-60^{\circ}\text{C} \leq \text{Ta} \leq 55^{\circ}\text{C}$

Degree of protection: IP67 (Match operation head)

Rated voltage: AC,DC6.3V~220V AC110V~380V

Power consumption:  $P_{\text{max}} \leq 1\text{W}$

Light source: LED

Electric life: 300,000 hours

Cable diameter:  $\Phi 5.5\text{--}13\text{mm}$

Standard: IEC60079 IEC61241 EN60079 EN61241

A型罩面  
A cover face



B型罩面  
B cover face



## ZH-B款板后单元型防爆信号灯

ZH-B type explosion-proof signal lamp of board back unit type

CHFB 浙豪

### 订购规格 Order specifications

图样 Illustration	型号 Model	信号灯颜色 Colour of signal lamp	信号灯模块电压 The voltage of signal lamp module
 雾状型 Fog type	ZH-BADS	红 Red 绿 Green 黄 Yellow 蓝 Blue 白 White	AC110V~380V AC.DC6.3V~220V
 透明型 Tran spatent type	ZH-BBDJ		

### 外型尺寸 Outline dimensions

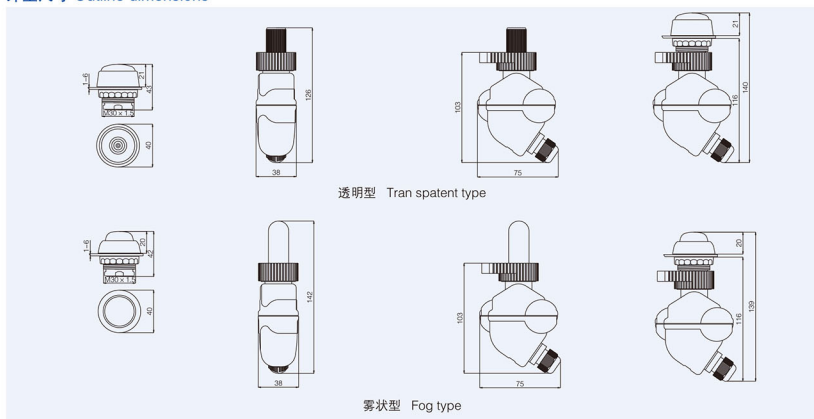

### 安装间距 Mounting distance

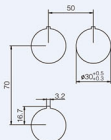

## ZH-B款板后单元型防爆信号灯带按钮

ZH-B type explosion-proof signal lamp with button of board back unit type

**CHFB 浙豪**

### 主要数据 Main technical data:

防爆标志: Ex de II C T6 DIP A21 TA, T6

适用范围: 用于1区和2区

使用环境温度:  $-60^{\circ}\text{C} \leq \text{Ta} \leq 55^{\circ}\text{C}$

防护等级: IP67 (配合操作头)

按钮: 约定封闭发热电流: 10A

额定电压: 250V | 24V

使用类别: AC15 | DC13

额定电流: 6A | 1A

机械寿命: 30万次

信号灯: 光源: LED

功耗:  $P_{\text{max}} \leq 1\text{W}$

额定电压: AC.DC6.3V~220V AC110V~380V

电气寿命: 30万小时

电缆引入外径:  $\Phi 5.5 \sim 13\text{mm}$

符合标准: IEC60079 IEC61241 EN60079 EN61241

Ex mark: Ex de II C T6 DIP A21 TA, T6

Application: zone 1 and zone 2

Ambient temperature:  $-60^{\circ}\text{C} \leq \text{Ta} \leq 55^{\circ}\text{C}$

Degree of protection: IP67 (Match operation head)

Button: Conventional enclosed thermal current: 10A

Rated voltage: 250V | 24V

Category: AC15 | DC13

Rated current: 6A | 1A

Mechanical life: 300,000 times

Signal lamp: Light source: LED

Power consumption:  $P_{\text{max}} \leq 1\text{W}$

Rated voltage: AC.DC6.3V~220V AC110V~380V

Electric life: 300,000 hours

Cable diameter:  $\Phi 5.5 \sim 13\text{mm}$

Standard: IEC60079 IEC61241 EN60079 EN61241

### 订购规格 Order specifications

	型号 Model	信号灯颜色 Colour of signal lamp	按钮触点 Button contact	信号灯电压 The voltage of signal lamp
	ZH-B01D/B10D	红Red 绿Green 黄Yellow 蓝Blue 白White	常开或常闭 1NO or 1NC	AC.DC6.3V~220V AC110V~AC380V

带灯柱: 绿色、黄色、白色、蓝色均为一常开, 红色为常闭。button with light: green, yellow, white and blue are for one normally open, red color is for one normally closed.

### 外型尺寸 Outline dimensions

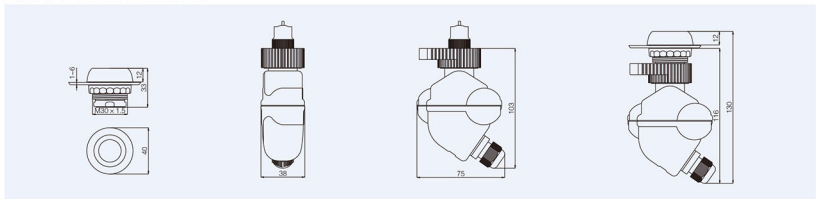

### 安装间距 Mounting distance

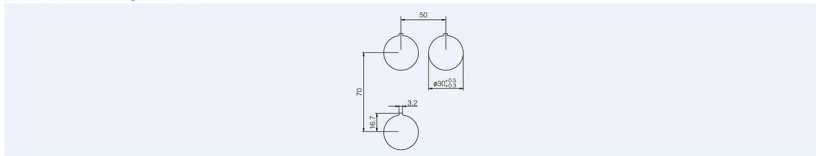

# ZH-B款板后单元型防爆电位器

ZH-B type explosion-proof potentiometer of board back unit type

## 主要数据 Main technical data:

防爆标志: Exde II C T6 DIP A21 TA,T6

适用范围: 用于1区和2区

使用环境温度:  $-60^{\circ}\text{C} \leq \text{Ta} \leq 55^{\circ}\text{C}$

防护等级: IP66(配合操作头)

额定电压/功耗:  $250\text{V} / \leq 2\text{W}$

刻度:  $0 \sim 300^{\circ}$  单圈

$0 \sim 360^{\circ} \times 10$  多圈

电缆引入外径:  $\Phi 5.5 \sim 13\text{mm}$

符合标准: IEC60079 IEC61241 EN60079 EN61241

Ex mark: Ex de II C T6 DIP A21 TA, T6

Application: zone 1 and zone 2

Ambient temperature:  $-60^{\circ}\text{C} \leq \text{Ta} \leq 55^{\circ}\text{C}$

Degree of protection: IP66 (Match operation head)

Rated voltage/ Power consumption:  $250\text{V} / \leq 2\text{W}$

Scale:  $0 \sim 300^{\circ}$  single turn



$0 \sim 360^{\circ} \times 10$  multi turn

Cable diameter:  $\Phi 5.5 \sim 13\text{mm}$

Standard: IEC60079 IEC61241 EN60079 EN61241



## 订购规格 Order specifications

图样 Illustration	名称 Name	型号 Model	电阻值 Resistance value	功耗 Power consumption
	单圈电位器 Single turn potentiometer	ZH-BW1	1000 $\Omega$ 2200 $\Omega$ 4700 $\Omega$ 10000 $\Omega$	$\leq 2\text{W}$
	多圈电位器 Multi turn potentiometer	ZH-BW2		

注: 如需其它阻值, 可订做。 Note: for other resistance, can be customized.

## 外型尺寸 Outline dimensions

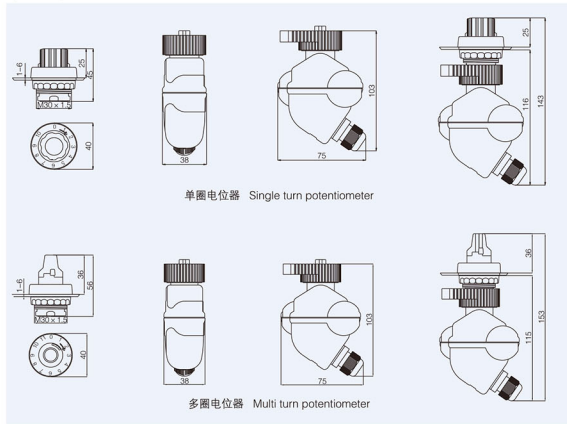

## 安装间距 Mounting distance

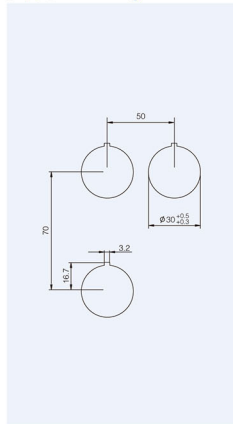

## ZH-A款板前、C款板后防爆元件

ZH-A type board front, C type board back, explosion-proof component

CHFB 浙豪

### 描述 Descriptions

板前型、板后型防爆元件的前端操作头标准直径为 $\Phi 30\text{mm}$ ，安装在1-6mm厚的面板上。板前型防爆元件安装在35mm标准导轨上；板后型模块借助一个卡口夹连接到预先安装好的前端操作头上。板前型、板后型防爆元件附带接线端子。

板前型、板后型防爆元件应安装在防护等级达IP57以上的增安型壳体内。

板前型、板后型防爆按钮、开关可选用多种不同功能的按钮操作头、开关操作头。

板前型、板后型防爆信号灯元件采用LED光源，内设温度开关、有五种颜色可以选择。

- 按钮的标识牌符号经烧结后可永久保留。
- 防爆开关的额定电流可达16A，机械寿命可达200万次。
- 防爆信号灯元件具有高亮度、长寿命等特点，电气寿命可达30万小时以上。

The standard diameter of front neck for explosion-proof panel back and board front module is 30mm. Thickness of installing panel should be 1-6mm. board front module are mounted in a 35mm rail. board back module are connected to the pre-mounted front operation head with a clamp. The terminals are attached to board back and board front module. board back and board front explosion-proof module should be installed in the increased safety enclosure which the protection degree is up to IP57.

A large number of versions of actuating elements are available for the button and indicator units

LED light source is used in explosion-proof signal lamp of board back and board front module type, and thermal switch is also build-in. There are five color available.

- The laser mark of button are never fade.
- Rated current of explosion-proof switch is 16A, and it is mechanical life is 2,000,000 times.
- The features of explosion-proof signal lamp are high brightness, long life, and its electric life is more than 300,000 hours.

### 主要数据

防爆标志： $\text{Ex}$  II 2G Ex de II C

适用范围：用于1区和2区

使用环境温度： $-60^{\circ}\text{C} \leq T_a \leq 55^{\circ}\text{C}$

防护等级：IP67

额定电压：	250V	250V	110V	24V
使用类别：	AC12	AC15	DC13	DC13
额定电流：	16A	10A	0.5A	1A
环境温度：	$T_a \leq 40^{\circ}\text{C}$	$T_a \leq 60^{\circ}\text{C}$	$T_a \leq 60^{\circ}\text{C}$	$T_a \leq 60^{\circ}\text{C}$

机械寿命：200万次

板前型安装：导轨TS35 x 7.5

板后型安装：在1-6mm面板上

符合标准：IEC60079 IEC61241 EN60079 EN61241

### Main technical data:

Ex mark:  $\text{Ex}$  II 2G Ex de II C

Application: zone 1 and zone 2

Ambient temperature:  $-60^{\circ}\text{C} \leq T_a \leq 55^{\circ}\text{C}$

Degree of protection: IP67

Rated voltage:	250V	250V	110V	24V
Category:	AC12	AC15	DC13	DC13
Rated current:	16A	10A	0.5A	1A
Ambient temperature:	$T_a \leq 40^{\circ}\text{C}$	$T_a \leq 60^{\circ}\text{C}$	$T_a \leq 60^{\circ}\text{C}$	$T_a \leq 60^{\circ}\text{C}$

Mechanical life: 2,000,000 times

Board front type mounting: DIN-rail TS35 x 7.5

Board back type mounting: On 1-6mm panel

Standard: IEC60079 IEC61241 EN60079 EN61241

### 适用范围 Applications

1. 1区、2区或20区、21区和22区危险场所；
2. II A、II B、II C类爆炸性气体环境；
3. 可燃性粉尘环境；
4. 有强腐蚀性气体环境。

1. Hazardous areas: Zone 1&2 or zone 20、21、22;
2. Explosive gas atmosphere: class II A、II B、II C;
3. Flammable dust atmospheres;
4. Strong corrosive gas environment;

1区和2区 Zone 1 and zone 2

21区和22区 Zone 21 and zone 22

## ZH-A款板前、C款板后防爆平钮

ZH-A type board front, C type board back explosion-proof flat button

### 型号及其含义 Model and meaning



### ZH-A/C款防爆按钮元件(Ⅱ C、DIP) ZH-A/C Explosion-proof switch component(Ⅱ C、DIP)

图样 Illustration	名称 Name	型号 Model	按钮触点 Button contact
	A款板前型平钮 A type board front type flat button	ZH-A11P	 一常开一常闭 (1NO/1NC)
		ZH-A02P	 二常闭(2NC)
		ZH-A20P	 二常开(2NO)
	C款板后型平钮 C type board back type flat button	ZH-C11P	 一常开一常闭 (1NO/1NC)
		ZH-C02P	 二常闭(2NC)
		ZH-C20P	 二常开(2NO)
	A款板前型双按钮 A type board front type double button	ZH-A11P2	 一常开一常闭 (1NO/1NC)
		ZH-A02P2	 二常闭(2NC)
		ZH-A20P2	 二常开(2NO)
	C款板后型双按钮 C type board back type double button	ZH-A11P2	 一常开一常闭 (1NO/1NC)
		ZH-A02P2	 二常闭(2NC)
		ZH-A20P2	 二常开(2NO)

## ZH-A款板前、C款板后防爆平钮

ZH-A type board front, C type board back explosion-proof flat button

### 外型尺寸 Outline dimensions

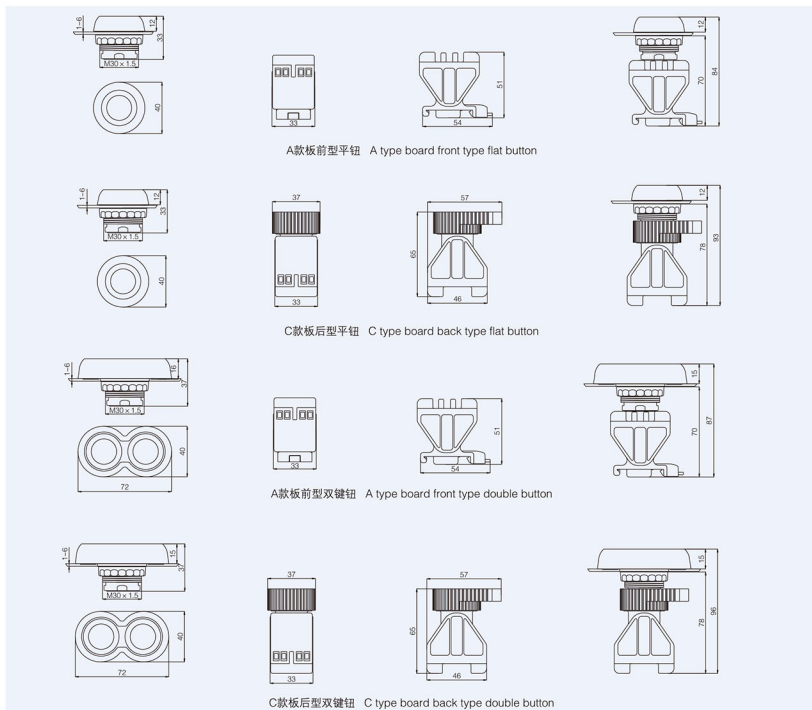

### 安装间距及开孔尺寸 Mounting distance and cut-out dimensions

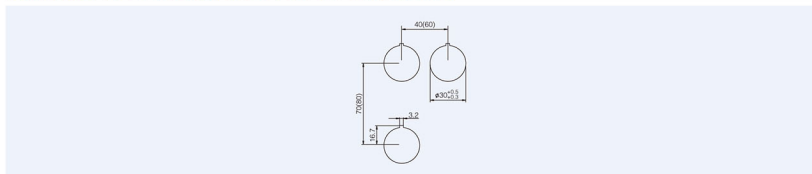

# ZH-A款板前、C款板后防爆急停按钮

ZH-A type board front, C type board back Explosion-proof emergency stop button

## 适用范围Applications

- |                            |  |
|----------------------------|--|
| 1. 1区、2区或20区、21区和22区危险场所;  | 1. Hazardous areas: Zone 1&2 or zone 20、21、22;     |
| 2. II A、II B、II C类爆炸性气体环境; | 2. Explosive gas atmosphere: class II A、II B、II C; |
| 3. 可燃性粉尘环境;                | 3. Flammable dust atmospheres;                     |
| 4. 有强腐蚀性气体环境。              | 4. Strong corrosive gas environment;               |

## 产品特点Features

- |                                  |   |
|----------------------------------|---|
| 1. 外壳由定制工程塑料注塑成型;                | 1. The shell is made by customized engineering plastics.  |
| 2. 内部弹簧抗老化处理, 连接螺丝及弹垫抗震动、防松特殊定制; | 2. The internal springs are treated anti-aging. Screw and spring washer are anti-knock, and shake proof.                  |
| 3. 本产品应与增安型壳体或与防爆外壳配套使用, 不可单独使用。 | 3. This product should be used together with increased safety enclosure or explosion-proof box, can't be used separately. |

## ZH-A/C款防爆按钮元件(II C、DIP) ZH-A/C Explosion-proof switch component(II C、DIP)

图样 Illustration	名称Name	型号 Model	按钮触点Button contact
	A款板前型旋式急停按钮 A type board front type rotary emergency stop button	ZH-A11ZX	 一常开一常闭 (1NO/1NC)
		ZH-A02ZX	 二常闭(2NC)
		ZH-A20ZX	 二常开(2NO)
	A款板前型直拔式急停按钮 A type board front type pull type emergency stop button	ZH-A11ZB	 一常开一常闭 (1NO/1NC)
		ZH-A02ZB	 二常闭(2NC)
		ZH-A20ZB	 二常开(2NO)
	C款板后型旋式急停按钮 C type board back type rotary emergency stop button	ZH-C11ZX	 一常开一常闭 (1NO/1NC)
		ZH-C02ZX	 二常闭(2NC)
		ZH-C20ZX	 二常开(2NO)
	C款板后型直拔式急停按钮 C type board back type pull type emergency stop button	ZH-C11ZB	 一常开一常闭 (1NO/1NC)
		ZH-C02ZB	 二常闭(2NC)
		ZH-C20ZB	 二常开(2NO)

## ZH-A款板前、C款板后防爆急停按钮

ZH-A type board front, C type board back Explosion-proof emergency stop button

### 外型尺寸 Outline dimensions

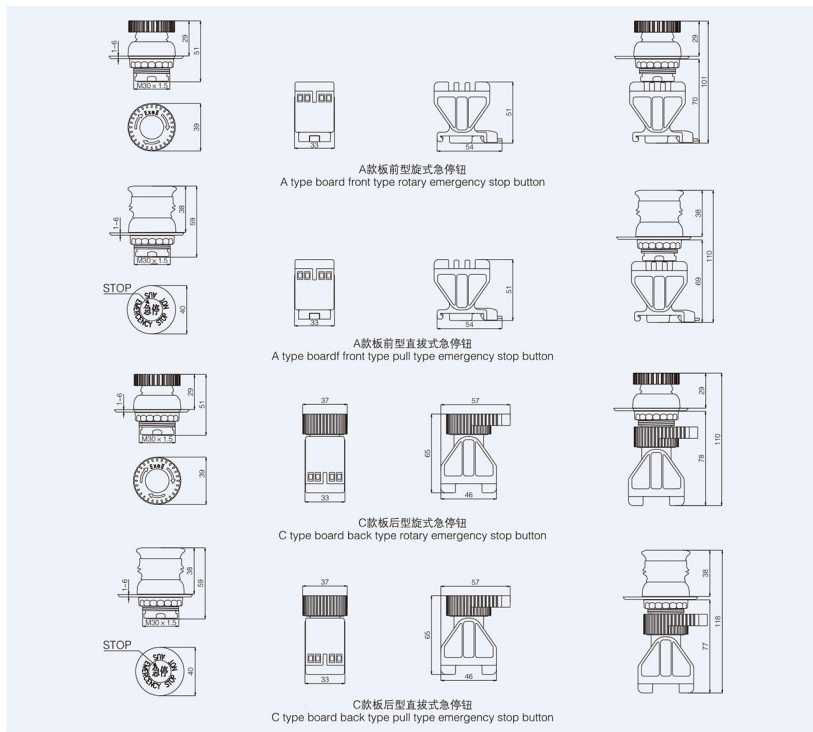

### 安装间距及开孔尺寸 Mounting distance and cut-out dimensions

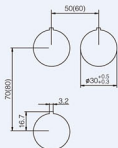

## ZH-A款板前、C款板后型防爆蘑菇按钮

ZH-A type board front, C type board back type explosion-proof mushroom button

### 适用范围 Applications

- |                            |  |
|----------------------------|--|
| 1. 1区、2区或20区、21区和22区危险场所;  | 1. Hazardous areas: Zone 1&2 or zone 20、21、22;     |
| 2. II A、II B、II C类爆炸性气体环境; | 2. Explosive gas atmosphere: class II A、II B、II C; |
| 3. 可燃性粉尘环境;                | 3. Flammable dust atmospheres;                     |
| 4. 有强腐蚀性气体环境。              | 4. Strong corrosive gas environment;               |

### 产品特点 Features

- 外壳由定制工程塑料注塑成型;
  - 内部弹簧抗老化处理, 连接螺丝及弹垫抗震动、防松特殊定制;
  - 本产品应与增安型壳体或与防爆外壳配套使用, 不可单独使用。
- The shell is made by customized engineering plastics.
  - The internal springs are treated anti-aging. Screw and spring washer are anti-knock, and shake proof.
  - This product should be used together with increased safety enclosure or explosion-proof box, can't be used separately.

### ZH-A/C款防爆按钮元件(II C、DIP) ZH-A/C Explosion-proof switch component(II C、DIP)

图样 Illustration	名称Name	型号Model	按钮触点Button contact
	A款板前型蘑菇按钮 A type board front type mushroom button	ZH-A11M1	 一常开一常闭 (1NO/1NC)
		ZH-A02M1	 二常闭(2NC)
		ZH-A20M1	 二常开(2NO)
	A款板前型蘑菇按钮 A type board front type mushroom button	ZH-A11M2	 一常开一常闭 (1NO/1NC)
		ZH-A02M2	 二常闭(2NC)
		ZH-A20M2	 二常开(2NO)
	C款板后型蘑菇按钮 C type board back type mushroom button	ZH-C11M1	 一常开一常闭 (1NO/1NC)
		ZH-C02M1	 二常闭(2NC)
		ZH-C20M1	 二常开(2NO)
	C款板后型蘑菇按钮 C type board back type mushroom button	ZH-C11M2	 一常开一常闭 (1NO/1NC)
		ZH-C02M2	 二常闭(2NC)
		ZH-C20M2	 二常开(2NO)

## ZH-A款板前、C款板后型防爆蘑菇按钮

ZH-A type board front, C type board back type explosion-proof mushroom button

### 外型尺寸 Outline dimensions



### 安装间距及开孔尺寸 Mounting distance and cut-out dimensions

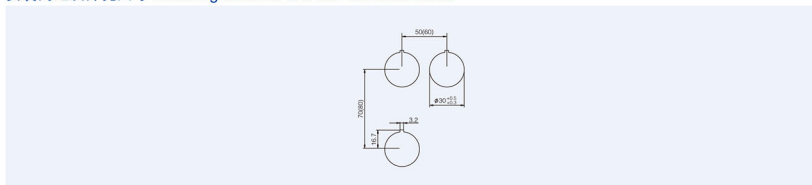

## ZH-A款板前、C款板后防爆二极开关元件

ZH-A type board front, C type board back 2-pole explosion-proof switch component

### 适用范围 Applications

- |                            |  |
|----------------------------|--|
| 1. 1区、2区或20区、21区和22区危险场所；  | 1. Hazardous areas: Zone 1&2 or zone 20、21、22;     |
| 2. II A、II B、II C类爆炸性气体环境； | 2. Explosive gas atmosphere: class II A、II B、II C; |
| 3. 可燃性粉尘环境；                | 3. Flammable dust atmospheres;                     |
| 4. 有强腐蚀性气体环境。              | 4. Strong corrosive gas environment;               |

### 产品特点 Features

- |                                 |   |
|---------------------------------|---|
| 1. 外壳由定制工程塑料注塑成型；               | 1. The shell is made by customized engineering plastics.  |
| 2. 内部弹簧抗老化处理，连接螺丝及弹垫抗震动、防松特殊定制； | 2. The internal springs are treated anti-aging. Screw and spring washer are anti-knock, and shake proof.                  |
| 3. 本产品应与增安型壳体或与防爆外壳配套使用，不可单独使用。 | 3. This product should be used together with increased safety enclosure or explosion-proof box, can't be used separately. |

### 订购规格 Order specifications

图样 Illustration	型号Model	标识牌 Label	操作位置接触图 Contact schematic for operating position
 <p>A type</p>	ZH-A11X3F2	0 I II	
	ZH-C11X3F2		
	ZH-A20X3F1	I 0 II	
	ZH-C20X3F1		
	ZH-A20X3F2	I 0 II	
	ZH-C20X3F2		
	ZH-A20X3	I 0 II	
	ZH-C20X3		
	ZH-A11X3	0 I II	
	ZH-C11X3	0 I	
ZH-A20X2	0 I		
ZH-C20X2	0 I		
ZH-A20X2F	0 I		
ZH-C20X2F	0 I		
ZH-A11X2	I II		
ZH-C11X2	I II		
ZH-A11X2F	I II		
ZH-C11X2F	I II		
ZH-A11X3F1	0 · I		
ZH-C11X3F1	0 · I		

## ZH-A款板前、C款板后防爆二极开关元件

ZH-A type board front, C type board back 2-pole explosion-proof switch component

### 外型尺寸 Outline dimensions

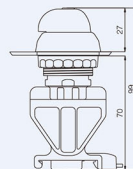
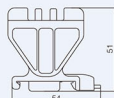
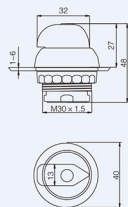

A款防爆转换开关 A type explosion-proof rotary switch

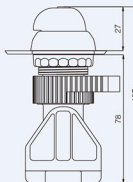
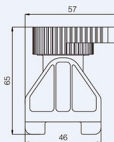
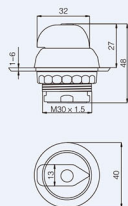

C款防爆转换开关 C type explosion-proof rotary switch

### 安装间距及开孔尺寸 Mounting distance and cut-out dimensions

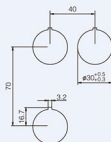

# ZH-A款板前、C款板后防爆信号灯元件

ZH-A type board front, C type board back explosion-proof signal lamp component

## 型号及其含义 Model and meaning

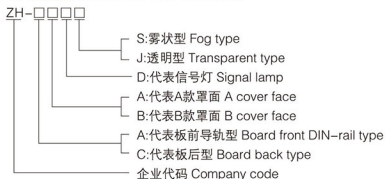

## 适用范围 Applications

- 1区、2区或20区、21区和22区危险场所；
  - II A、II B、II C类爆炸性气体环境；
  - 可燃性粉尘环境；
  - 有强腐蚀性气体环境。
1. Hazardous areas: Zone 1&2 or zone 20, 21, 22;
  2. Explosive gas atmosphere: class II A, II B, II C;
  3. Flammable dust atmospheres;
  4. Strong corrosive gas environment;

## 主要数据 Main technical data:

防爆标志: Ex de II C T6 DIP A21 TA,T6

适用范围: 用于1区和2区

使用环境温度:  $-60^{\circ}\text{C} \leq \text{Ta} \leq 55^{\circ}\text{C}$

防护等级: IP67(配合操作头)

额定电压: AC.DC6.3V~220V AC110V~380V

功耗:  $P_{\text{max}} \leq 1\text{W}$

光源: LED

电气寿命: 30万小时

符合标准: IEC60079 IEC61241 EN60079 EN61241

Ex mark: Ex de II C T6 DIP A21 TA,T6

Application: zone 1 and zone 2

Ambient temperature:  $-60^{\circ}\text{C} \leq \text{Ta} \leq 55^{\circ}\text{C}$

Degree of protection: IP67(Match operation head)

Rated voltage: AC.DC6.3V~220V AC110V~380V

Power consumption:  $P_{\text{max}} \leq 1\text{W}$

Light source: LED

Electric life: 300,000 hours

Standard: IEC60079 IEC61241

EN60079 EN61241

## 订购规格 Order specifications

图样 Illustration	型号 Model	信号灯颜色 Colour	信号灯模块电压 The voltage of signal lamp module
 雾状型 Fog type	ZH-AADS		
 透明型 Transparent type	ZH-ABDJ	红 Red 绿 Green 黄 Yellow	AC110V~380V
 雾状型 Fog shape type	ZH-CADS	蓝 Blue 白 White	AC.DC6.3V~220V
 透明型 Transparent type	ZH-CBDJ		

## ZH-A款板前、C款板后防爆信号灯元件

ZH-A type board front, C type board back explosion-proof signal lamp component

### 外型尺寸 Outline dimensions

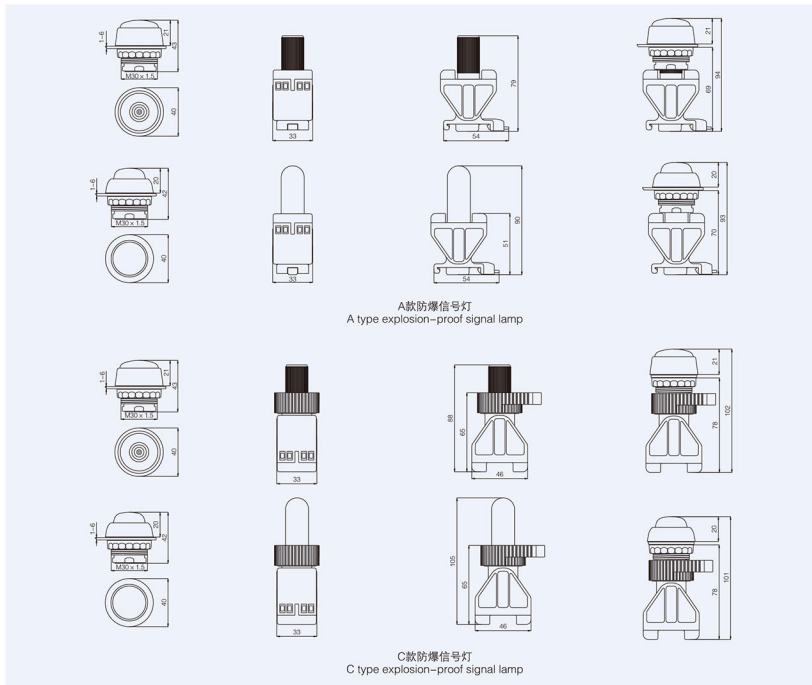

### 安装间距及开孔尺寸 Mounting distance and cut-out dimensions

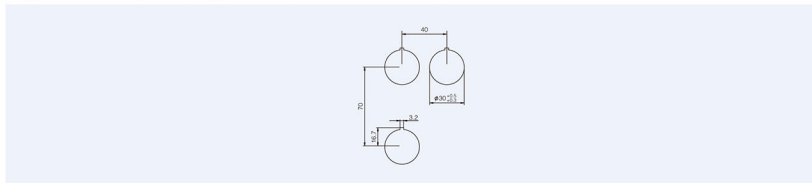

# ZH-A款板前、C款板后防爆信号灯带按钮元件

ZH-A type board front, C type board back explosion-proof signal lamp with button component

## 型号及其含义 Model and meaning



## 主要数据 Main technical data:

防爆标志: Ex de II C T6 DIP A21 TA,T6

适用范围: 用于1区和2区

使用环境温度:  $-60^{\circ}\text{C} \leq \text{Ta} \leq 55^{\circ}\text{C}$

防护等级: IP67(配合操作头)

按钮: 约定封闭发热电流: 10A

额定电压: 250V | 24V

使用类别: AC15 | DC13

额定电流: 6A | 1A

机械寿命: 30万次

信号灯: 光源: LED

功耗:  $\text{Pmax} \leq 1\text{W}$

额定电压: AC.DC6.3V-220V AC110V-380V

电气寿命: 30万小时

符合标准: IEC60079 IEC61241 EN60079 EN61241

Ex mark:Ex de II C T6 DIP A21 TA,T6

Application: zone 1 and zone 2

Ambient temperature:  $-60^{\circ}\text{C} \leq \text{Ta} \leq 55^{\circ}\text{C}$

Degree of protection:IP67(Match operation head)

Button: Conventional enclosed thermal current:10A

Rated voltage: 250V | 24V

Category: AC15 | DC13

Rated current: 6A | 1A

Mechanical life: 300,000 times

Signal lamp: Light source: LED

Power consumption:  $\text{Pmax} \leq 1\text{W}$

Rated voltage: AC.DC6.3V-220V AC110V-380V

Electric life: 300,000 hours

Standard: IEC60079 IEC61241 EN60079 EN61241

## 适用范围 Applications

- 1区、2区或20区、21区和22区危险场所;
- II A、II B、II C类爆炸性气体环境;
- 可燃性粉尘环境;
- 有强腐蚀性气体环境。

1. Hazardous areas: Zone 1&2 or zone 20、21、22;
2. Explosive gas atmosphere: class II A、II B、II C;
3. Flammable dust atmospheres;
4. Strong corrosive gas environment;

## 产品特点 Features







1. 外壳由定制工程塑料注塑成型;
2. 透明罩采用聚碳酸酯注塑成型;
3. 信号灯的发光光源为LED, 具有超长寿命 $\geq 30$ 万小时, 节能、环保等性能。
4. 本产品应与增安型壳体或与防爆外壳配套使用, 不可单独使用。

1. The shell is made by customized engineering plastics.
2. Transparent cover is made by polycarbonate
3. LED light source is used in explosion-proof signal lamp. It has more than 300,000 hours life time, with good performance of energy saving, and environmental protection.
4. This product should be used together with increased safety enclosure or explosion-proof box, can't be used separately.

# ZH-A款板前、C款板后防爆信号灯带按钮元件

ZH-A type board front, C type board back explosion-proof signal lamp with button component

## 订购规格 Order specifications

图样 Illustration	型号 Model	信号灯颜色 Colour of signal lamp	按钮触点 Button contact	信号灯电压 The voltage of signal lamp
	ZH-A10D	红Red 绿Green 黄Yellow 蓝Blue 白White	 1NO	AC110V-380V  AC,DC6.3V-220V
	ZH-A01D		 1NC	
	ZH-C10D		 1NO	
	ZH-C01D		 1NC	

带灯钮：绿色、黄色、白色、蓝色均为一常开，红色为常闭。button with light: green, yellow, white and blue are for one normally open, red color is for one normally closed.

## 外型尺寸 Outline dimensions

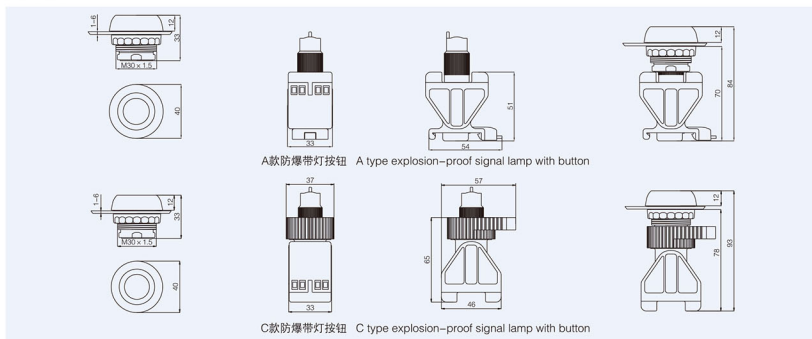

## 安装间距及开孔尺寸 Mounting distance and cut-out dimensions

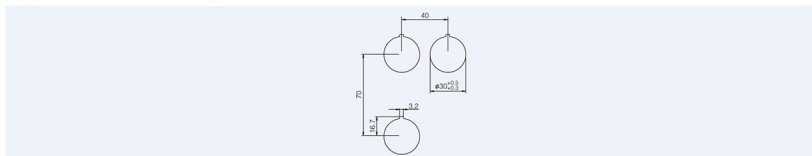

# ZH-A款板前、C款板后防爆电位器元件

ZH-A type board front, C type board back explosion-proof potentiometer component

## 型号及其含义 Model and meaning



## 适用范围 Applications

1. 1区、2区或20区、21区和22区危险场所;
2. II A、II B、II C类爆炸性气体环境;
3. 可燃性粉尘环境;
4. 有强腐蚀性气体环境。
1. Hazardous areas: Zone 1&2 or zone 20、21、22;
2. Explosive gas atmosphere: class II A、II B、II C;
3. Flammable dust atmospheres;
4. Strong corrosive gas environment;

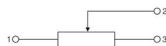

## 主要数据 Main technical data:

防爆标志: Exde II C T6 DIP A21 TA, T6

适用范围: 用于1区和2区

使用环境温度:  $-60^{\circ}\text{C} \leq \text{Ta} \leq 55^{\circ}\text{C}$

防护等级: IP66(配合操作头)

额定电压/功耗:  $250\text{V} / \leq 2\text{W}$

刻度:  $0 \sim 300^{\circ}$  单圈

$0 \sim 360^{\circ} \times 10$  多圈

符合标准: IEC60079 IEC61241 EN60079 EN61241

Ex mark: Ex de II C T6 DIP A21 TA, T6

Application: zone 1 and zone 2

Ambient temperature:  $-60^{\circ}\text{C} \leq \text{Ta} \leq 55^{\circ}\text{C}$

Degree of protection: IP66(Match operation head)

Rated voltage/ Power consumption:  $250\text{V} / \leq 2\text{W}$

Scale:  $0 \sim 300^{\circ}$  single turn

$0 \sim 360^{\circ} \times 10$  multi turn

Standard: IEC60079 IEC61241 EN60079 EN61241

## 订购规格 Order specifications

图样 Illustration	名称 Name	型号 Model	电阻值 Resistance value	功耗 Power consumption
	A款单圈电位器 A Single turn potentiometer	ZH-AW1	1000Ω 2200Ω 4700Ω 10000Ω	≤2W
	A款多圈电位器 A Multi turn potentiometer	ZH-AW2		
	B款单圈电位器 B Single turn potentiometer	ZH-CW1		
	B款多圈电位器 B Multi turn potentiometer	ZH-CW2		

注: 如需其它阻值, 可订做。 Note: for other resistance, can be customized.

## ZH-A款板前、C款板后防爆电位器元件

ZH-A type board front, C type board back explosion-proof potentiometer component

### 外型尺寸 Outline dimensions

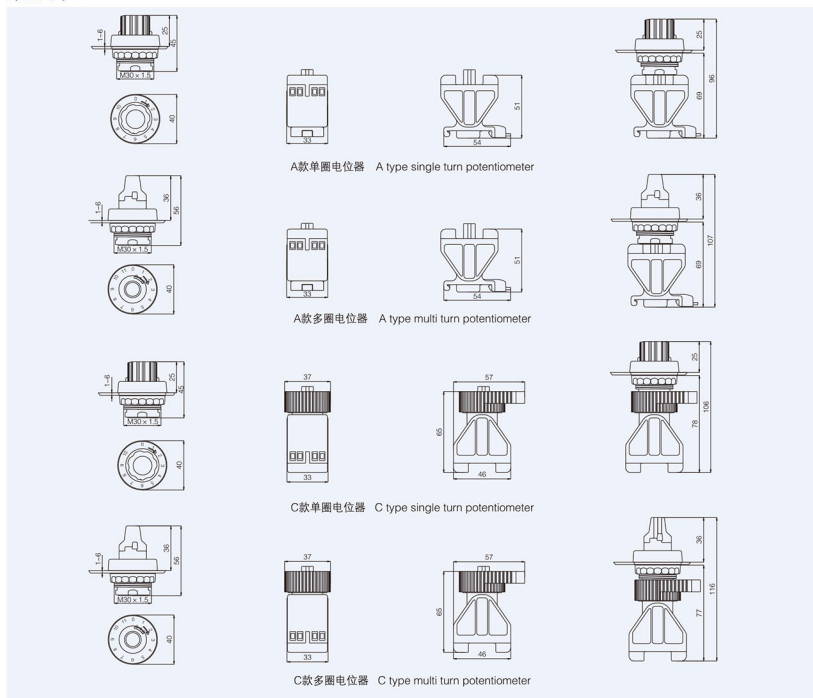

### 安装间距及开孔尺寸 Mounting distance and cut-out dimensions

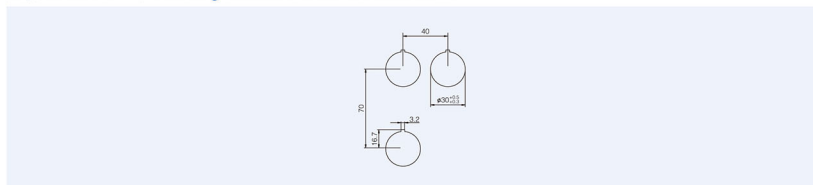

### 型号及其含义 Model and meaning

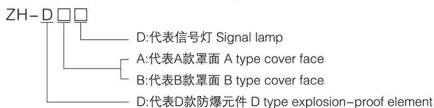

### 技术参数 Technical parameters

防爆标志Ex-mark	Ex de II C T6 DIP A21 TA,T6
信号灯模块电压 Signal lamp module voltage	AC/DC6.3~220V, AC110V~380V
功耗 Power loss	P ≤ 1W
颜色 Colour	红色:R、绿色:G、黄色:Y、蓝色:B、白色:W
光源 Light source	LED

### 适用范围 Applications

- 1区、2区或20区、21区和22区危险场所；
- II A、II B、II C类爆炸性气体环境；
- 可燃性粉尘环境；
- 有强腐蚀性气体环境。

1. Hazardous areas: Zone 1&2 or zone 20, 21, 22;
2. Explosive gas atmosphere: class II A, II B, II C;
3. Flammable dust atmospheres;
4. Strong corrosive gas environment;

### 产品特点 Features

1. 透明件由聚碳酸酯注塑成型；
2. 本产品应与增安型壳体或与防爆外壳配套使用，不可单独使用。

1. Transparent part is made by polycarbonate
2. This product should be used together with increased safety enclosure or explosion-proof box, can't be used separately.

### 外型尺寸 Outline dimensions

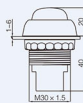

D款a型罩面防爆信号灯  
D type a series cover face  
explosion-proof signal lamp

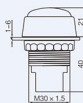

D款b型罩面防爆信号灯  
D type b series cover face  
explosion-proof signal lamp

# ZH-D款板后型防爆按钮

ZH-D type board back type explosion-proof push button



## 型号及其含义 Model and meaning



## 主要数据 Main technical data:

防爆标志: Ex II 2G Ex de II C

适用范围: 用于1区和2区

使用环境温度:  $-60^{\circ}\text{C} \leq \text{Ta} \leq 55^{\circ}\text{C}$

防护等级: IP67

额定电压: 250V | 250V | 110V | 24V

使用类别: AC12 | AC15 | DC13 | DC13

额定电流: 16A | 10A | 0.5A | 1A

环境温度:  $\text{Ta} \leq 40^{\circ}\text{C}$  |  $\text{Ta} \leq 60^{\circ}\text{C}$  |  $\text{Ta} \leq 60^{\circ}\text{C}$  |  $\text{Ta} \leq 60^{\circ}\text{C}$

机械寿命: 100万次

板后型安装: 在1-6mm面板上

符合标准: IEC60079 IEC61241 EN60079 EN61241

Ex mark: Ex II 2G Ex de II C

Application: zone 1 and zone 2

Ambient temperature use:  $-60^{\circ}\text{C} \leq \text{Ta} \leq 55^{\circ}\text{C}$

Degree of protection: IP67

Rated voltage: 250V | 250V | 110V | 24V

Category: AC12 | AC15 | DC13 | DC13

Rated current: 16A | 10A | 0.5A | 1A

Ambient temperature:  $\text{Ta} \leq 40^{\circ}\text{C}$  |  $\text{Ta} \leq 60^{\circ}\text{C}$  |  $\text{Ta} \leq 60^{\circ}\text{C}$  |  $\text{Ta} \leq 60^{\circ}\text{C}$

Mechanical life: 1,000,000 times

Installation of board back type: On 1-6mm panel

Standard: IEC60079 IEC61241 EN60079 EN61241

## 外型尺寸 Outline dimensions

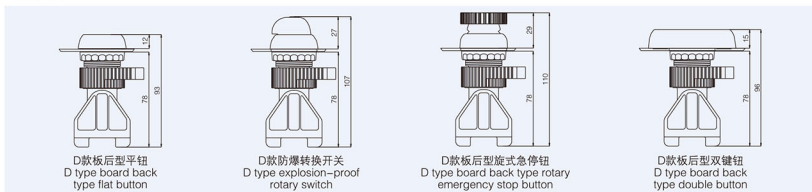

## ZH-E款板后型防爆按钮(隔爆型)

ZH-E type board back type explosion-proof push button  
(flameproof)

CHFB 浙豪



平钮 Flat button



带灯按钮 Signal lamp with button



二位置选择按钮 Two position selector button



旋式急停按钮 Rotary type emergency stop button

### 型号及其含义 Model and meaning

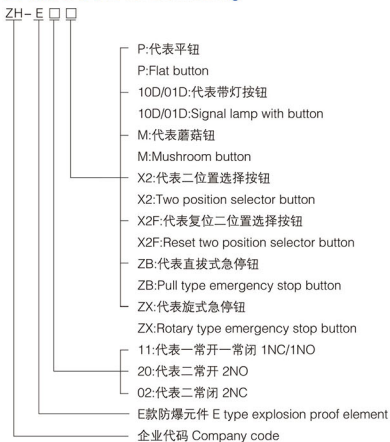

### 适用范围 Applications

1. 1区、2区或20区、21区和22区危险场所;
  2. II A、II B、II C类爆炸性气体环境或可燃性粉尘环境。
1. Hazardous areas: Zone 1&2 or zone 20、21、22;  
2. Explosive gas atmosphere: class II A、II B、II C or Flammable dust atmospheres.

### 产品特点 Features

1. 本产品由铝合金、不锈钢或中碳钢制成;
  2. 同隔爆型箱配套使用,不可单独用于爆炸性气体环境。
1. This products are made by aluminum alloy, stainless steel or medium carbon steel  
2. The explosion-proof signal lamp should be used together with flame proof enclosure, can't be used alone at explosive atmosphere.

## ZH-E 款板后型防爆按钮(隔爆型)

ZH-E type board back type explosion-proof push button  
(flameproof)

**CHFB 浙豪**

### 技术参数 Technical parameters

额定容量 Rated capacity	AC-15	200V/6A 380V/4A 600V/2A
	DC-13	24V/6A 480V/3A 110V/1A 220V/0.5A
防爆标志 Ex-mark		Exd IIB Gb Exd IIC Gb DIP A20
防护等级 Degree of protection		IP65 IP66*

### 外型尺寸 Outline dimensions

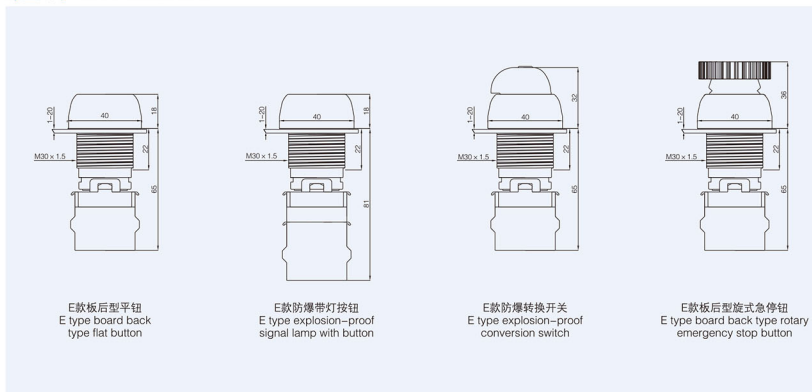

### 安装间距及开孔尺寸 Mounting distance and cut-out dimensions

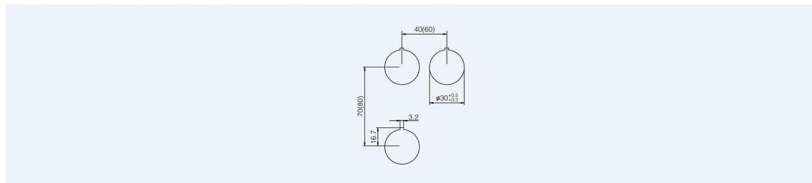

## ZH-E款板后型防爆信号灯(隔爆型)

ZH-E type board back type explosion-proof signal lamp  
(flameproof)

CHFB 浙豪



### 型号及其含义 Model and meaning

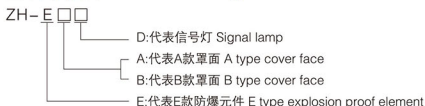

### 技术参数 Technical parameters

防爆标志Ex-mark	Ex d II C T6 DIP A21 TA,T6
信号灯模块电压 Signal lamp module voltage	AC/DC6.3~220V, AC110V~380V
功耗 Power consumption	P ≤ 1W
颜色 Colour	红色:R、绿色:G、黄色:Y、蓝色:B、白色:W
光源 Light source	LED

### 适用范围 Applications

1. I区、2区或20区、21区和22区危险场所；
  2. II A、II B、II C类爆炸性气体环境；
  3. 可燃性粉尘环境；
  4. 有强腐蚀性气体环境。
1. Hazardous areas: Zone 1&2 or zone 20、21、22;
  2. Explosive gas atmosphere: class II A、II B、II C;
  3. Flammable dust atmospheres;
  4. Strong corrosive gas environment;

### 产品特点 Features

1. 本产品由铝合金、不锈钢或中碳钢制成；
  2. 同隔爆型箱配套使用，不可单独用于爆炸性气体环境。
1. This products are made by aluminum alloy, stainless steel or medium carbon steel
  2. The explosion-proof signal lamp should be used together with flame proof enclosure, can't be used alone at explosive atmosphere.

### 外型尺寸 Outline dimensions

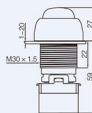

E款a型罩面防爆信号灯  
E type a series cover face  
explosion-proof signal lamp

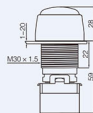

E款b型罩面防爆信号灯  
E type b series cover face  
explosion-proof signal lamp

## ZH-F款板后防爆信号灯元件

ZH-F type board back explosion-proof signal lamp component

### 型号及其含义 Model and meaning

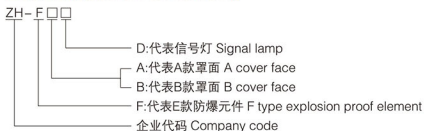

### 主要数据 Main technical data:

防爆标志: Ex de II C T6 DIP A21 TA,T6

适用范围: 用于1区和2区

使用环境温度:  $-60^{\circ}\text{C} \leq \text{Ta} \leq 55^{\circ}\text{C}$

防护等级: IP67(配合操作头)

额定电压: AC.DC6.3V~220V AC110V~380V

功耗:  $P_{\text{max}} \leq 1\text{W}$

光源: LED

电气寿命: 30万小时

符合标准: IEC60079 IEC61241 EN60079 EN61241

Ex mark: Ex de II C T6 DIP A21 TA,T6

Application: zone 1 and zone 2

Ambient temperature:  $-60^{\circ}\text{C} \leq \text{Ta} \leq 55^{\circ}\text{C}$

Degree of protection: IP67(Match operation head)

Rated voltage: AC.DC6.3V~220V AC110V~380V

Power consumption:  $P_{\text{max}} \leq 1\text{W}$

Light source: LED

Electric life: 300,000 hours

Standard: IEC60079 IEC61241 EN60079 EN61241

### 适用范围 Applications

1. 1区、2区或20区、21区和22区危险场所;
  2. II A、II B、II C类爆炸性气体环境;
  3. 可燃性粉尘环境;
  4. 有强腐蚀性气体环境。
1. Hazardous areas: Zone 1&2 or zone 20、21、22;
  2. Explosive gas atmosphere: class II A、II B、II C;
  3. Flammable dust atmospheres;
  4. Strong corrosive gas environment;

### 产品特点 Features

1. 本产品由铝合金、不锈钢或中碳钢制成;
  2. 同增安箱、隔爆型箱配套使用, 不可单独用于爆炸性气体环境。
1. This products are made by aluminum alloy, stainless steel or medium carbon steel
  2. It should be used with increased safty enclosure and flame-proof enclosure, and can't be used alone in explosive atmosphere.

## ZH-F款板后防爆信号灯元件

ZH-F type board back explosion-proof signal lamp component

**CHFB 浙豪**

### 订购规格 Order specifications

图样 Illustration	型号 Model	信号灯颜色 Colour	信号灯模块电压 The voltage of signal lamp module
	ZH-FAD	红 Red 绿 Green 黄 Yellow	AC110V-380V
	ZH-FBD	蓝 Blue 白 White	AC.DC6.3V-220V

### 外型尺寸 Outline dimensions

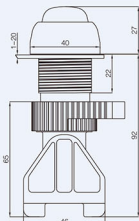

F款a型罩面防爆信号灯  
F type a series cover face explosion-proof signal lamp

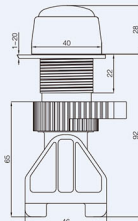

F款b型罩面防爆信号灯  
F type b series cover face explosion-proof signal lamp

### 安装间距及开孔尺寸 Mounting distance and cut-out dimensions

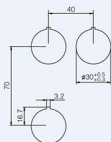

# ZH-F款板后型防爆按钮

ZH-F type board back type explosion-proof push button

## 型号及其含义 Model and meaning

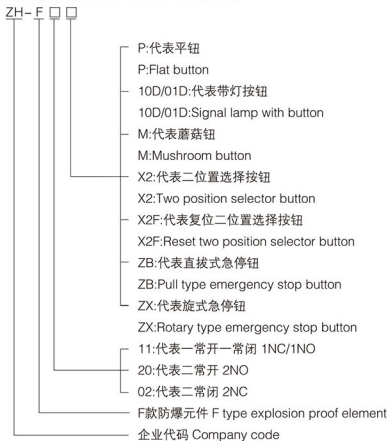

## 适用范围 Applications

1. 1区、2区或20区、21区和22区危险场所;
2. II A、II B、II C类爆炸性气体环境;
3. 可燃性粉尘环境;
4. 有强腐蚀性气体环境。
1. Hazardous areas: Zone 1&2 or zone 20、21、22;
2. Explosive gas atmosphere: class II A、II B、II C;
3. Flammable dust atmospheres;
4. Strong corrosive gas environment;

1区和2区 Zone 1 and zone 2

21区和22区 Zone 21 and zone 22

## 主要数据

防爆标志: (Ex) II 2G Ex de II C

适用范围: 用于1区和2区

使用环境温度:  $-60^{\circ}\text{C} \leq \text{Ta} \leq 55^{\circ}\text{C}$

防护等级: IP67

额定电压:	250V	250V	110V	24V
使用类别:	AC12	AC15	DC13	DC13
额定电流:	16A	10A	0.5A	1A
环境温度:	$\text{Ta} \leq 40^{\circ}\text{C}$	$\text{Ta} \leq 60^{\circ}\text{C}$	$\text{Ta} \leq 60^{\circ}\text{C}$	$\text{Ta} \leq 60^{\circ}\text{C}$

机械寿命: 200万次

板后型安装: 在1-20mm面板上

符合标准: IEC60079 IEC61241 EN60079 EN61241

## Main technical data:

Ex mark: (Ex) II 2G Ex de II C

Application: zone 1 and zone 2

Ambient temperature:  $-60^{\circ}\text{C} \leq \text{Ta} \leq 55^{\circ}\text{C}$

Degree of protection: IP67

Rated voltage:	250V	250V	110V	24V
Category:	AC12	AC15	DC13	DC13
Rated current:	16A	10A	0.5A	1A
Ambient temperature:	$\text{Ta} \leq 40^{\circ}\text{C}$	$\text{Ta} \leq 60^{\circ}\text{C}$	$\text{Ta} \leq 60^{\circ}\text{C}$	$\text{Ta} \leq 60^{\circ}\text{C}$

Mechanical life: 2,000,000 times

Board back type mounting: On 1-20mm panel

Standard: IEC60079 IEC61241 EN60079 EN61241

## 产品特点 Features

1. 本产品由铝合金、不锈钢或中碳钢制成;
2. 同增安箱、隔爆型箱配套使用, 不可单独用于爆炸性气体环境。
1. This products are made by aluminum alloy, stainless steel or medium carbon steel
2. It should be used with increased safety enclosure and flame-proof enclosure, and can't be used alone in explosive atmosphere.

订购规格 Order specifications

图样 Illustration	名称 Name	型号 Model	按钮触点 Button contact
	F款防爆按钮 F type explosion-proof button	ZH-F11P	 一常开一常闭 (1NO/1NC)
		ZH-F02P	 二常闭(2NC)
		ZH-F20P	 二常开(2NO)
	F款防爆带灯按钮 F type explosion-proof signal lamp with button	ZH-F10D	 一常开(1NO)
		ZH-F01D	 一常闭(1NC)
	F款防爆二级开关 F type Two position explosion-proof pushbutton	ZH-F11X2	 一常开一常闭 (1NO/1NC)
		ZH-F02X2	 二常闭(2NC)
		ZH-F20X2	 二常开(2NO)
	F款防爆急停按钮 F type Explosion-proof emergency stop button	ZH-F11ZX	 一常开一常闭 (1NO/1NC)
		ZH-F02ZX	 二常闭(2NC)
		ZH-F20ZX	 二常开(2NO)

外型尺寸 Outline dimensions

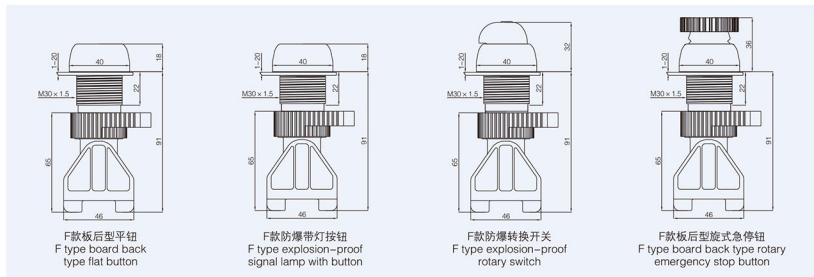

## ZH-BXK-L/G/S防爆防腐防尘控制箱(操作柱)

ZH-BXK-L/G/S Explosion proof, corrosion proof and dust proof control box (Operating column)

CHFB 浙豪



### 描述 Descriptions

防爆控制箱(操作柱)系列有多种外壳尺寸供选择:内置多个板前型、板后型防爆元件,外壳采用耐冲击的抗静电玻璃纤维增强聚酯、铝合金、不锈钢304等材料制成,能承受最极端的工业运行条件。盖和基座的结合面设计成凹凸形,设有发泡硅橡胶密封结构,确保了IP66防护等级。

操作柱有壁式和立式二种安装形式,配有专用的立柱脚盘和不锈钢防护罩。内装防爆元件模块安装在面板上或外壳内的标准35mm导轨上。按用户要求电缆入口可设在顶部或底部,可配有配制电缆密封套或金属电缆密封套。

There are different sizes and materials available for explosion proof enclosure (operating column), in which number of board front type or board back type explosion-proof components can be built-in. The materials of enclosure are antistatic and impact resistance glass fiber reinforced polyester, aluminium alloy and stainless steel of SUS304. It can work under most extreme conditions of industrial operation. The concave and convex joint is designed between the cover and base, and they are sealed by foam silicone rubber ring, to ensure the degree of protection IP66.

The two installation ways of operation column are vertical type and wall type. Special column base and stainless steel shield are equipped. The explosion-proof modules are mounted on panel of enclosure, or on the standard 35mm DIN-rail in side of enclosure. The cable entrance can be arranged on the top or bottom of enclosure according user's request. Plastic or metal cable gland can be equipped alternatively.

### 适用范围Applications

- 适用于爆炸性气体环境1区, 2区场所
- 适用于IIA IIB IIC类爆炸性气体环境
- 适用于可燃性粉尘环境21区, 22区场所
- 适用于T1-T6
- 广泛用于化工及石化工业, 石油平台, 机械工程, 炼油厂等易燃易爆气体环境, 也用于军工, 金属加工及其它行业可燃性粉尘加工场所
- Explosive gas atmosphere: Zone 1, Zone 2, A, B, C
- Explosive gas atmosphere: IIA IIB IIC
- Flammable dustatmosphere: Zone 21, zone 22
- Suitable for T1-T6
- It is widely used in inflammable and explosive gas atmosphere, such as chemical industry, petrochemical industry, oil platform, mechanical engineering, oil refinery, and it also used military industry, metal processing and other inflammable dust field.

## ZH-BXK-L/G/S防爆防腐防尘控制箱(操作柱)

ZH-BXK-L/G/S Explosion proof, corrosion proof and dust proof control box (Operating column)

CHFB 浙豪

### 产品特点 Features

- 外壳为母块结构可根据客户需要自由组合, 内装防爆元件(按钮, 信号灯, 电流表, 电位器, 转速表, 急停按钮, 转换开关及带灯钮)。
- 防爆内装元件安装方便, 元件安装方式: 板后安装和板前导轨式安装(导轨式安装结构能快速安装在带定位的导轨上, 方便安装, 维修, 维护)。
- 防爆内装元件根据要求可配防误操作结构(保护罩可分为透明和黄色警示两种, 可挂锁)
- 工程塑料采用增强玻璃纤维不饱和聚酯树脂模压外壳, 具有抗冲击, 热稳定性好, 耐强酸, 强碱, 盐, 氨, 氯离子腐蚀。
- 壳体, 壳盖接合处为迷宫式防水结构, 硅橡胶密封条, 耐酸, 耐碱, 耐油, 耐高温, 抗老化, 具有良好的防水, 防尘, 防腐性能。
- 铝合金外壳表面高压静电喷塑料, 不锈钢外露紧固件。
- 不锈钢外壳采用304不锈钢材质焊接成型, 不锈钢外形美观, 防掉结构, 防爆螺丝开盖后脱落, 方便安装和检修密封条耐酸, 耐碱, 耐油, 耐高温, 抗老化, 具有良好的防水, 防尘, 防腐, 防爆, 防锈性能。
- Shells are module type, so they can be combined freely according to user's request. Build-in are Explosion proof components(push button, signal lamp, ampere meter, potentiometer, tachometer, emergency stop push button, rotary switch and illuminated push button)
- Easy installation for explosive-proof component. Installation type: board back mounting and board front din-rail mounting(DIN-rail type is a fast installation type, it is convenient for maintain and repair)
- According to request, explosive component can be equipped with anti-misoperation mechanism. (two type of protective cover are transparent and yellow, padlock is available)
- The enclosure is make of reinforced glass fiber unsaturated polyester resin, it is impact resistance, good thermal stability, resistance to strong acid and alkali, salt, ammonia, chloridion.
- Joint of enclosure cover and base are labyrinth waterproof structure. It is sealed by silicone rubber ring. It is strong resistance to acid and alkali, oil, high temperature, aging with good function of waterproof, dustproof, anti-corrosion
- Surface of aluminum alloy enclosure is high pressure electrostatic plastic-spray with stainless steel fastener.
- 304 stainless steel enclosure are made by welding process. Stainless steel enclosure is beautiful shape with special anti-drop structure to prevent screw from dropping after open enclosure.

### 型号及其含义 Model and meaning

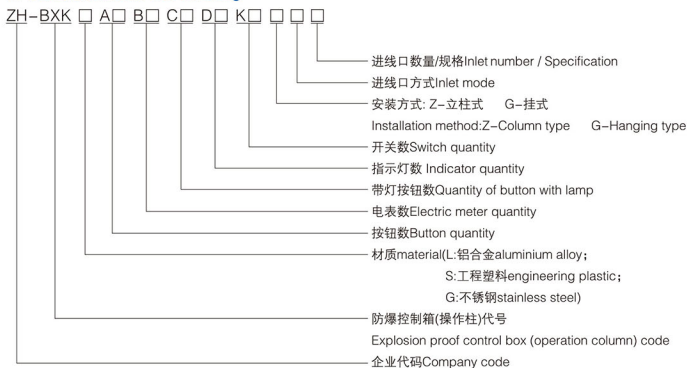

ZH-BXK-L/G/S防爆防腐防尘控制箱(操作柱)  
ZH-BXK-L/G/S Explosion proof, corrosion proof and dust proof control  
box (Operating column)

CHFB 浙豪

外型尺寸 Outline dimensions

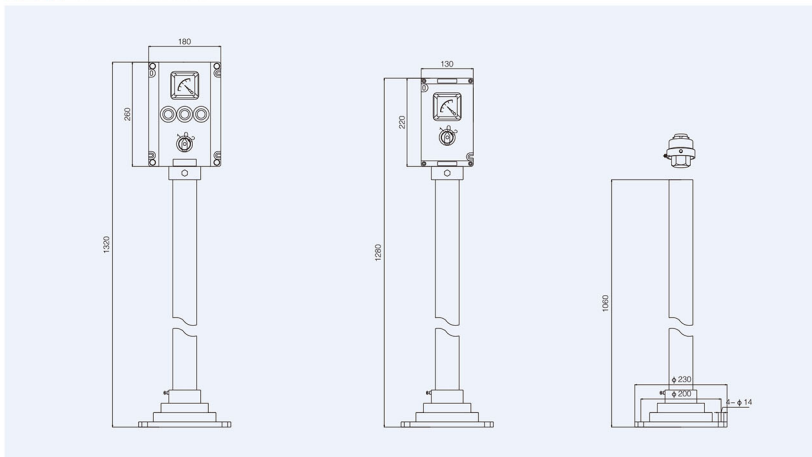

操作头Actuators	L(mm)
平钮Flat button	12
双键钮Double button	15
旋式急停自锁按钮Rotary type emergency self-locking button	29
直拔式急停自锁按钮 Pull type emergency self-locking button	38
黑色蘑菇头按钮 Black mushroom head button	29
开关操作头 Switch operation head	27
信号灯A罩面 A cover face of signal lamp	20
信号灯C罩面 C cover face of signal lamp	21
电位器操作头 Operation head of potentiometer	36
信号灯带按钮 Signal lamp with button	12

# ZH-BXK-L/G/S防爆防腐防尘控制箱(操作柱)

ZH-BXK-L/G/S Explosion proof, corrosion proof and dust proof control box (OPERating column)



## 方案举例 Examples for selection

图样 Illustration	方案 Scheme

# ZH-BXK-L/G/S防爆防腐防尘控制箱(操作柱)

ZH-BXK-L/G/S Explosion proof, corrosion proof and dust proof control box (Operating column)

## 方案举例 Examples for selection

图样 Illustration	方案 Scheme

注：控制箱（操作柱）全塑、铝材质，外观尺寸已定型，可选型，不锈钢可订制。本目录箱体尺寸仅展示部分，如需其它尺寸请来电。  
 Note: the size of control box (operation column) of plastic and aluminum material, has been finalized, but stainless steel can be customized. This catalog box size is only part of the display, if you need other sizes, please call.

防爆电缆夹紧密封接头 Explosion proof cable clamp sealing joint

英制接头(G) British joint (G)

管螺纹 Pipe thread	管通径 Pipe diameter	电缆外径 Cable outer dia.
G1/2	15	Φ7-Φ10
G3/4	20	Φ10-Φ14
G1	25	Φ12-Φ18
G1 1/4	32	Φ15-Φ26
G1 1/2	40	Φ18-Φ30
G2	50	Φ25-Φ37

公制接头(M) Metric joint (M)

规格 Specification	螺纹 Screw thread	电缆外径 Cable outer dia.
M16	M16 × 1.5	Φ5-Φ10
M20	M20 × 1.5	Φ6-Φ12
M25	M25 × 1.5	Φ10-Φ14
M32	M32 × 1.5	Φ13-Φ19
M40	M40 × 1.5	Φ17-Φ26
M50	M50 × 1.5	Φ24-Φ36
M63	M63 × 1.5	Φ37-Φ44



Φ30mm 安装手柄  
Φ30mm installing handle



Φ30mm 面板塞  
Φ30mm panel plug



Φ30mm 标牌框(L:35mmXW:8mm)  
Φ30mm label frame



Φ30mm 标牌框(L:35mmXW:16mm)  
Φ30mm label frame



Φ30mm 防护盖  
Φ30mm protective cover



Φ30mm 防护盖  
Φ30mm protective cover